

ATTENTION: WARRANTY AGAINST DEFECTS

A copy of this warranty is also available at www.seatingdynamics.com.au.
Warranty period: 12 months limited.

1. Seating Dynamics Pty Ltd ABN 21 086 494 117 ("SDL") undertakes to the end purchaser (the "Customer") that the Products will be free of faults arising from defects in Workmanship or Materials for the duration of the Warranty Period on the terms and conditions set out in this Warranty.
2. In this Warranty the following definitions apply:
 - a. Form means a warranty claim form issued by Seating Dynamics Pty Ltd in respect of the Products.
 - b. Products means the goods distributed or sold by SDL set out in the table above.
 - c. Material means a material or component used by the manufacturer in the manufacture of Products distributed and/or sold by SDL.
 - d. Retailer means the authorised dealer of Products from whom the Customer purchased the Product.
 - e. Warranty Period means the warranty period set out in the table above, commencing from the date of purchase of the Product by the Customer.
 - f. Workmanship means the handling, assembly and manufacturing processes performed by or on behalf of SDL in order to manufacture the Products.
3. SDL undertakes that if the Customer wants to make a claim during the Warranty Period for any Product, or any part of a Product that has failed to operate correctly as a result of faulty Workmanship or defective Material, SDL will subject to this Warranty, repair or replace the Product or part (as the case may be) free of charge (excluding freight costs) to the Customer as long as the following conditions are met:
 - a. The Customer must contact the Retailer or SDL (whose contact details are located at the bottom of this Warranty), as soon as the Customer becomes aware of any defect in the Product. The Customer will be required to complete a Form and provide to SDL satisfactory proof of the date of purchase of the Product;
 - b. SDL will review the Form and determine whether there is a defect;
 - c. If SDL requests the return of the applicable Product or part, the Customer will be responsible for the collection and freight costs of returning that Product or part to SDL; and
 - d. The Customer must pay all applicable freight costs when claiming under this warranty.
4. If the Product or part (as the case may be) is repaired or replaced during the Warranty Period, this Warranty remains based on the original date of purchase.
5. The benefits given to the Customer in this Warranty are in addition to any other rights or remedies under a law in relation to the Products to which the Warranty applies.
6. This Warranty does not extend to damage to Products which occurs during transit/transportation, or loading/unloading before or after transit/transportation, or which is caused by any abuse, accident or improper installation, connection, use, adjustment or repair or use of goods otherwise than in accordance with instructions issued by SDL.
7. To the extent permitted by law, the warranty on Products is waived if any addition or attachment to the Products does not have SDL's approval or are not sold as SDL Products. The Products are designed to perform specific tasks under established test loads and unauthorised attachments may produce stresses for which the design is not appropriate.
8. The following applies to Customers who purchased the Product in Australia: In the following paragraph "goods" means "Products" and "you" means the "Customer".

Our goods come with guarantees that cannot be excluded under the Australian Consumer Law. You are entitled to a replacement or refund for a major failure and compensation for any other reasonably foreseeable loss or damage. You are also entitled to have the goods repaired or replaced if the goods fail to be of acceptable quality and the failure does not amount to a major failure.

9. Notwithstanding the preceding paragraph, the liability of SDL for a breach of a consumer guarantee or any warranty made under these Warranty terms for any Products not of a kind ordinarily acquired for personal, domestic or household use is limited, to the extent permissible by law and at the option of SDL in relation to the Products supplied, to:
 - a. The replacement of the Products or the supply of equivalent Products;
 - b. The repair of the Products;
 - c. The payment of the cost of replacing the Products or of acquiring equivalent Products; or
 - d. The payment of the costs of having the Products repaired.
10. To the extent permitted by law, all other warranties whether implied or otherwise that are not set out in this Warranty are excluded and SDL shall be under no liability in contract, tort (including without limitation, negligence or breach of statutory duty) or otherwise to compensate the Customer for:
 - a. Increased costs or expenses;
 - b. Any loss of profit, revenue, business, contracts or anticipated savings;
 - c. Any loss or expense resulting from a claim by a third party; or
 - d. Any special, indirect or consequential losses or damage of any nature whatsoever caused by SDL's failure to complete or delay in completing the order to deliver the Products.
11. This Warranty is not applicable outside Australia.



CONTACT INFORMATION

Glen Curtin
Seating Dynamics Pty Ltd.
Unit 3A, 6 Boundary Rd, Northmead, NSW 2152
Telephone: 1 300 845 483, Int +61 2 8838 3100
Facsimile: +61 2 9012 0087
Email: info@seatingdynamics.com.au

For more information on Bodypoint products, and a list of distributors outside the USA go to www.bodypoint.com.



MDS GmbH
Schiffgraben 41
D-30175 Hannover
Germany



CHEST BELT

INSTALLATION AND USER'S INSTRUCTIONS

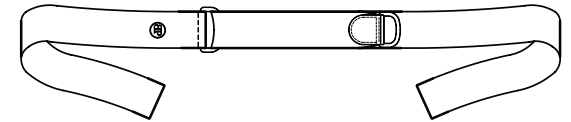

ART NOS. SH102-B1, SH102-B2, SH102P-B1, SH102P-B2



Bodypoint®

558 First Ave. South, Suite 300 | Seattle, WA 98104
206.405.4555 | 800.547.5716
www.bodypoint.com | email: info@bodypoint.com

BPI086-au 2014.5

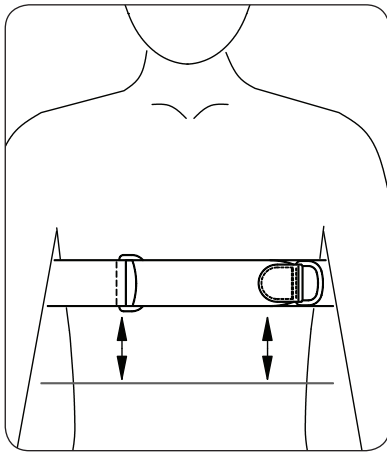

Fig. 1

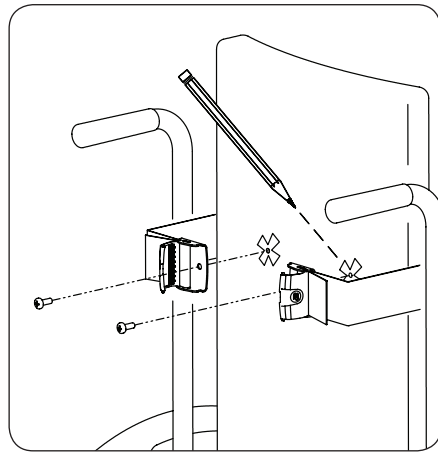

Fig. 2

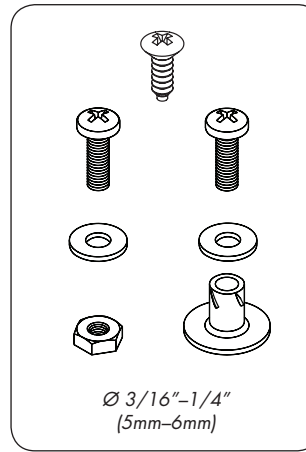

Fig. 3

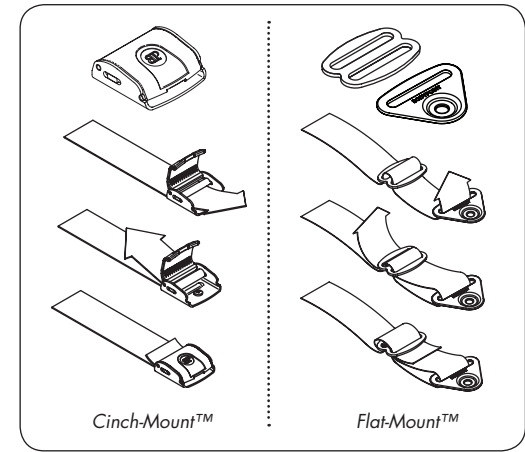

Fig. 4

PACKAGE CONTENTS

- Chest Belt or Padded Chest Belt
- Cinch-Mount™ or Flat-Mount™ End Fittings

These instructions provide important information for the safe use and maintenance of all Bodypoint Chest Belts. Give these instructions to the user or their caregiver and review them to ensure that they are understood.

⚠ WARNING! This product should be installed and fitted by a qualified rehab technician.

⚠ WARNING! Because of the risk of choking, it is dangerous to use this product without stabilizing the pelvis – always use with a properly fitted pelvic support belt.

POSITIONING: Seat user in wheelchair and establish correct posture with pelvic support belt. Determine desired position for the Chest Belt. (Fig. 1) To reduce the risk of strangulation and trunk instability, the belt should be neither too high nor too low. When choosing position, consider interference with other devices.

INSTALLATION:

Solid back wheelchair

1. Insert straps into end fittings. Wrap straps around backrest. Mark holes for reference. (Fig. 2)
2. Attach end fittings to backrest. Mounting screws must have a minimum pullout strength of 200lbs /90kg. Not included in package. (Fig. 3)

Optional mounting hardware available from Bodypoint

- Cam Buckles (Art. No. FS034-2)
- FrameSaver Clamps (Art. No. HW303-B-2)

ADJUSTMENT: Position user in wheelchair and fasten the pelvic support belt securely. With Chest Belt properly adjusted and the strap tightened, it should fit snug so the user's trunk is secure. Small adjustments in fit are done by using the adjustment strap. Large adjustment in fit are accomplished at the end fittings.

SAFETY CHECK: When properly positioned in wheelchair, have user lean forward and side to side to check fit. Check for:

1. Normal operation of adjustment strap.
2. Comfort – If any rubbing occurs relocate belt.
3. Position – If too high or too low, adjust mounting location.
4. Interference with other devices – Relocate belt as necessary to clear armrests, accessory pads, or feeding tubes.

USE:

⚠ WARNING! This product should only be used for positioning a person in a wheelchair. It is NOT intended for use as a transportation safety device, as a personal restraint device, or in any other application where its failure could result in injury. Misuse of this product is unauthorized and unsafe.

⚠ WARNING! Accidental release of this chest belt can allow the user to slip down or fall from the wheelchair. If the user's movements or cognitive abilities could lead to accidental

release, a caregiver must be present at all times during its use. Ensure that all caregivers know how to unfasten the product. Failure to do so may delay release in an emergency.

⚠ WARNING! As with any new seating support, this product may change the way a person sits. Users must continue to practice regular pressure relief activities and skin integrity checks, not only where this product contacts the user, but also in primary pressure-bearing areas such as the sacrum, legs, and buttocks. If increased skin redness or irritation occurs, discontinue use and consult your physician or seating specialist. Failure to do so may result in serious injury, such as pressure ulcers.

MAINTENANCE: Check periodically for signs of wear in the stitching, webbing, and pads. If significant wear is found, contact your supplier for qualified repair or replacement by Bodypoint. Under no circumstance should this product be altered or repaired by unqualified persons – health and safety depend on it!

🧼 CLEANING: Machine wash, warm, 40°C (100°F). Do not bleach. Tumble dry, low temperature, or drip dry. Do not iron. (Placing the product inside a cloth bag during washing helps prevent scratches to the product and the machine.)